

STANDARD LINEAR BOOTH

DEFINITION

One or more standard 10'x10' units in a straight line configuration.

HEIGHT

Exhibit, fixtures, components and identification signs will be permitted to a maximum height of 10'. (An 8' pipe and drape is provided along the back with 3' side rails.)

INTENT

If a portion of an exhibit booth extends above 10' high, the exhibit booth background will detract from the overall impact of the exhibit directly behind that booth regardless of how the rear of the offending exhibit is finished.

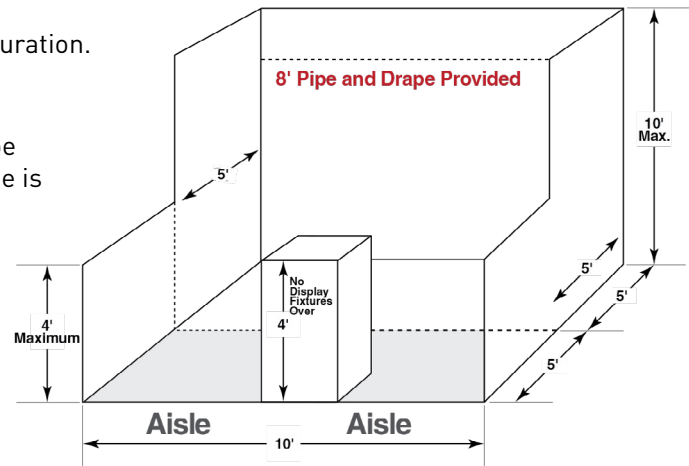

DEPTH

All display fixtures over 4' in height and placed within 10 linear feet of an adjoining exhibit must be confined to that area of the exhibitor's space, which is at least 5' from the aisle line. (Please refer to diagram.)

INTENT

Each exhibitor is entitled to a reasonable sight line from the aisle regardless of the size of exhibit. Exhibitors with large space—30 linear feet or more—should also be able to effectively use as much of the total floor space as possible as long as they do not interfere with the rights of others. The limitation on display fixtures over 4' and within 10 linear feet of a neighboring exhibit is intended to accomplish both of these aims.

IMPORTANT!

Space dimensions shown on floor plan are from centerline of booth equipment, such as side rails and/or back drape. Exhibit structures must be constructed to allow sufficient tolerance on each side for this equipment and for utility service at rear of booth.

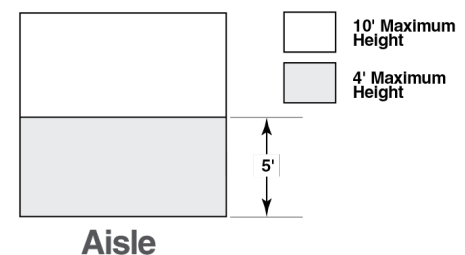

LINE-OF-SIGHT

Line-of-sight display rules provide restrictions on certain areas of booths to allow attendees to view neighboring booths in their line of sight as they walk the floor.

The ability to have products or services easily seen by attendees as they walk the aisles is essential to all exhibitors and that is the basis for including a linear booth line-of-site setback rule. Linear booths, also called "in-line" booths, are generally arranged in a straight line and have neighboring exhibits on their immediate left and right, leaving only one side exposed to the aisle.

Regardless of the number of linear booths, display materials should be arranged in such a manner so as not to obstruct site lines of neighboring exhibitors.

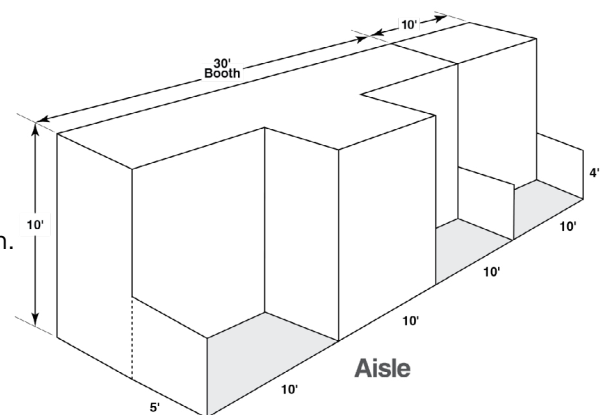

GRAPHICS

Signage and Graphics facing directly into a neighboring booth over the 8' high drape must be free of graphics or signage.